

Level switch**RFS-9-2****FEATURES**

- Pressures up to 40 bar
- All 316 grade stainless steel
- 120°C maximum temperature
- N/O or N/C contact
- 1/8" BSP Thread with nut
- 220Vac/50VA

OPTIONS

- Top entry - See DataFax 1514
- Multi-level - See DataFax 1526

REED SWITCH PROTECTION

When a reed-switch is used on an inductive load e.g. a relay - the current surge which flows back to the reed-switch (back EMF) can cause the reed switch to fail.

Fitting a suppressor either "in-line" or "across" the relay coil can help protect the reed-switch.

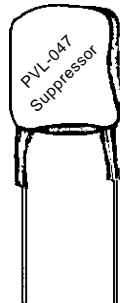
**SUPPRESSORS**

PVL 047-1 12 & 24Vdc = £1.60 each
 PVL 047-2 110Vac = £1.60 each
 PVL 047-3 240Vac = £2.20 each

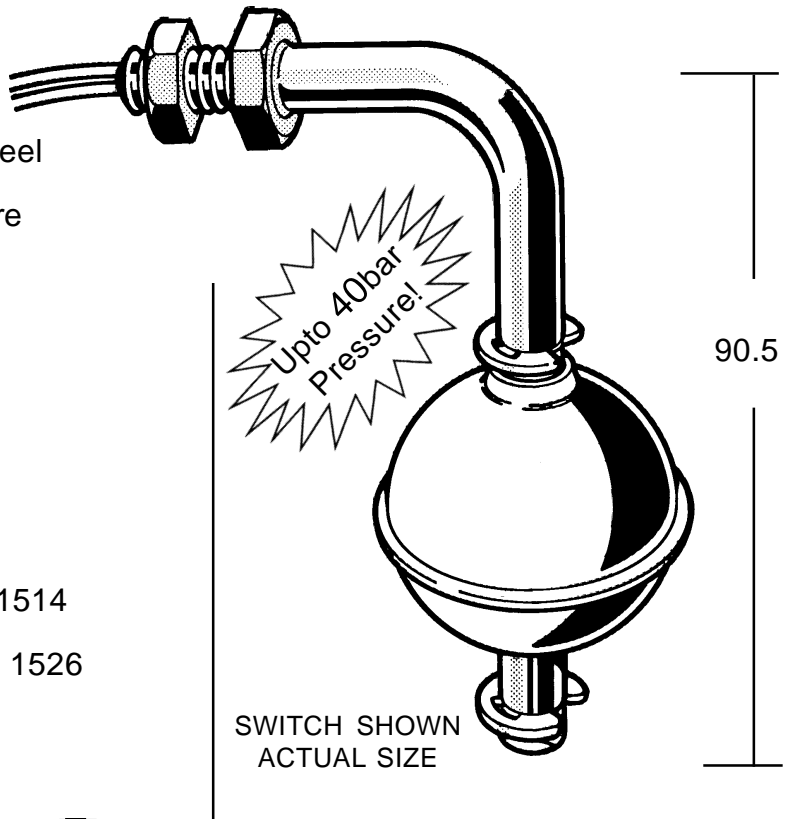
**REVERSIBLE FLOAT**

To change from a N/O to a N/C contact, simply remove the circlip and reverse the float on the stem.

OEM Price

RFS-9-2 = £26.99 each

Quantity discounts?
 phone for details

Maximum voltage	240Vac	Float material	316 stainless steel
Reed switch rating	50VA	Stem material	316 stainless steel
Maximum current	0.5A (resistive)	Float dimensions	43mm diameter
Maximum pressure & temp	40 bar & 120°C	Float bouyancy	0.55 SG
Thread	1/8" BSP x 15mm L	Circlip material	316 stainless steel

PRESSURE-VACUUM-LEVEL LTD

Unit 9, Lexden Lodge Industrial Estate, Jarvis Brook,
 Crowborough, East Sussex, TN6 2EG U.K.

Tel: +44(0)1892 66 44 99 Fax: +44(0)1892 66 36 90

See the Cat at: www.pvl.co.uk

PVL
Switched on to Industry